

(19) World Intellectual Property Organization
International Bureau



(43) International Publication Date
20 February 2003 (20.02.2003)

PCT

(10) International Publication Number
WO 03/013706 A1

(51) International Patent Classification⁷: B01D 65/02

[AU/AU]; 7 Howe Street, Westmead, NSW 2145 (AU).
STUBBS, Anthony, James [AU/AU]; 30 Hinkler Avenue,
Ryde, NSW 2112 (AU).

(21) International Application Number: PCT/AU02/01065

(22) International Filing Date: 8 August 2002 (08.08.2002)

(74) Agent: BALDWIN SHELSTON WATERS; 60 Margaret
Street, Sydney, NSW 2000 (AU).

(25) Filing Language: English

(26) Publication Language: English

(30) Priority Data:
PR 6924 9 August 2001 (09.08.2001) AU

(81) Designated States (*national*): AE, AG, AL, AM, AT, AU,
AZ, BA, BB, BG, BR, BY, BZ, CA, CH, CN, CO, CR, CU,
CZ, DE, DK, DM, DZ, EC, EE, ES, FI, GB, GD, GE, GH,
GM, HR, HU, ID, IL, IN, IS, JP, KE, KG, KP, KR, KZ, LC,
LK, LR, LS, LT, LU, LV, MA, MD, MG, MK, MN, MW,
MX, MZ, NO, NZ, OM, PH, PL, PT, RO, RU, SD, SE, SG,
SI, SK, SL, TJ, TM, TN, TR, TT, TZ, UA, UG, US, UZ,
VC, VN, YU, ZA, ZM, ZW.

(71) Applicant (*for all designated States except US*): U.S.
FILTER WASTEWATER GROUP, INC. [US/US]; 181
Thorn Hill Road, Warrendale, PA 15086 (US).

(84) Designated States (*regional*): ARIPO patent (GH, GM,
KE, LS, MW, MZ, SD, SL, SZ, TZ, UG, ZM, ZW),
Eurasian patent (AM, AZ, BY, KG, KZ, MD, RU, TJ, TM),
European patent (AT, BE, BG, CH, CY, CZ, DE, DK, EE,

(72) Inventors; and

(75) Inventors/Applicants (*for US only*): ZHA, Fufang

[Continued on next page]

(54) Title: METHOD OF CLEANING MEMBRANE MODULES

(57) Abstract: A method of cleaning a membrane filtration module (6), the module (6) including at least one membrane (8) located in a feed-containing vessel (7), the membrane (8) having a permeable wall which is subjected to a filtration operation wherein feed containing contaminant matter is applied to one side of the membrane wall and filtrate is withdrawn from the other side of the membrane wall. The method comprising the steps of: suspending the filtration operation; performing a cleaning process on the membrane wall to dislodge contaminant matter therefrom into liquid surrounding the membrane (8); performing a high velocity sweep of the feed-containing vessel (7) to remove the liquid containing the dislodged contaminant matter; and recommencing the filtration operation. An improved gas scouring method is also disclosed.

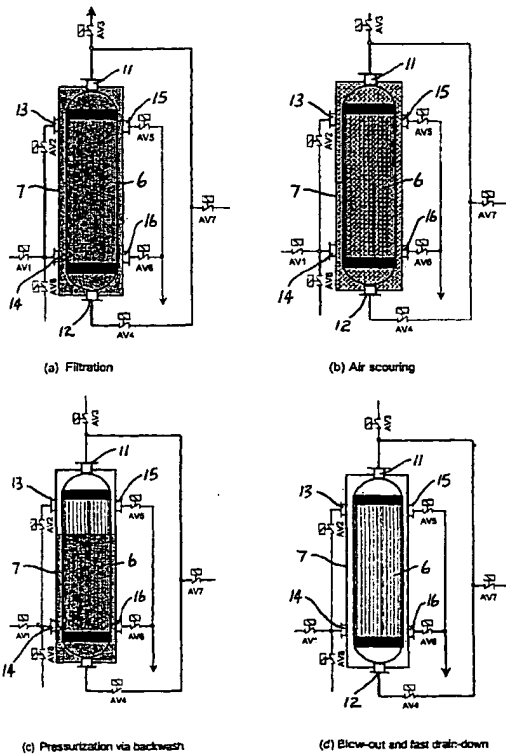

Membrane Cleaning Sequence



WO 03/013706 A1



ES, FI, FR, GB, GR, IE, IT, LU, MC, NL, PT, SE, SK,
TR), OAPI patent (BF, BJ, CF, CG, CI, CM, GA, GN, GQ,
GW, ML, MR, NE, SN, TD, TG).

Published:

— *with international search report*

Declaration under Rule 4.17:

— *of inventorship (Rule 4.17(iv)) for US only*

For two-letter codes and other abbreviations, refer to the "Guidance Notes on Codes and Abbreviations" appearing at the beginning of each regular issue of the PCT Gazette.

- 1 -

TITLE: METHOD OF CLEANING MEMBRANE MODULES

FIELD OF THE INVENTION

The present invention relates to membrane filtration systems and, more particularly, to a method and apparatus for improving the filtration efficiency of such systems by providing an improved cleaning system for the membranes.

BACKGROUND ART

Any discussion of the prior art throughout the specification should in no way be considered as an admission that such prior art is widely known or forms part of common general knowledge in the field.

10 In a membrane filtration process, the method used to physically clean membranes is of vital importance. An efficient membrane cleaning strategy can maintain a stable permeability of the membrane and reduce the frequency of chemical cleans. A commonly used method to physically clean membranes is a backwash (also called "backflush" or "backpulse") with the permeate/filtrate or a
15 gas. The backwash method is typically used to eject solids blocking the membrane pores and partly dislodge the cake that may have formed on the membrane surface.

Backwash with pressurized gas has proved a very efficient cleaning method and is now widely used in the field of microfiltration processes. The
20 limitation to this method is the membrane pore size. Backwash of membranes with permeate has no limitations to the pore size, but the backwash efficiency is generally lower than gas backwash and the transmembrane pressure (TMP) recovery not enough to offset the fouling rate. Further means are employed to enhance the backwash efficiency, such as dosing chemicals to the backwash
25 permeate, or in combination with gas scrubbing.

- 2 -

Maruyama et al in Japanese Patent No. JP2031200 discloses a hollow fibre membrane backwashing method. The method involves the following sequence: stop filtration, air-scour membrane, fill the membrane vessel, backwash with permeate under pressurized air and drain the waste. This procedure is repeated to achieve a higher efficiency. Sunaoka et al in a United States Patent No. 5,209,852 describes a process for scrubbing hollow fibre membranes in modules. This process is composed of a two-stage air scrubbing and draining to clean the membranes.

A lot of effort has been made to more effectively lift solids accumulated on the membrane surface and in the pores by optimising the backwash pressure and enhancing the air scrubbing efficiency. Another important step to achieve an efficient cleaning, which has been largely ignored, is the removal of solids that have been exfoliated off the membrane, from the membrane modules. The typical methods presently used are by draining down of the waste or by feed-and-bleed. Feed and bleed involves continual bleeding of waste containing feed out of the filtration system. The outcome is the accumulation of solids within the modules, particularly towards the two ends of a module and the effect becomes more serious if the membranes are densely packed in a module.

DISCLOSURE OF THE INVENTION

It is an object of the present invention to overcome or at least ameliorate one or more of the disadvantages of the prior art outlined above or at least provide a useful alternative.

According to one aspect, the present invention provides a method of cleaning a membrane filtration module, said module including at least one membrane located in a feed-containing vessel, the membrane having a

- 3 -

permeable wall which is subjected to a filtration operation wherein feed containing contaminant matter is applied to one side of the membrane wall and filtrate is withdrawn from the other side of the membrane wall, the method comprising the steps of:

- 5 a) suspending the filtration operation;
- b) performing a cleaning process on the membrane wall to dislodge contaminant matter therefrom into liquid surrounding the membrane;
- c) performing a high velocity sweep of the feed-containing vessel to remove the liquid containing the dislodged contaminant matter; and
- 10 d) recommencing the filtration operation.

Preferably, the cleaning process of step b) includes a fluid backwash of the membrane pores. For preference, the fluid backwash includes a liquid and /or gas backwash. For further preference, the cleaning process includes gas scrubbing of the surface of the membrane.

- 15 Preferably, the sweep of the feed-containing vessel is performed periodically in different directions within the vessel during operation of the cleaning method.

The contaminant matter may include solids, soluble species or other material removed from the feed during the filtration process.

20 BRIEF DESCRIPTION OF DRAWINGS

Preferred embodiments and examples of the invention will now be described, by way of example only, with reference to the accompanying drawings in which:

- 25 Figure 1 shows a schematic representation of the membrane module assembly according to one embodiment of the invention;

- 4 -

Figures 2a to 2d show schematic representations of the membrane module of Figure 1 during the membrane cleaning sequence according to the invention;

Figure 3 shows a graph of transmembrane pressure (TMP) versus time for the module of Figure 1 illustrating cleaning efficiencies of various backwash regimes;

Figure 4 shows a graph of transmembrane pressure (TMP) versus time for the module of Figure 1 illustrating the effect of the high velocity sweep on membrane cleaning;

Figure 5 shows a schematic representation of a membrane module according to a further embodiment of the present invention; and

Figure 6 shows a graph of transmembrane pressure (TMP) versus time for the module of Figure 5 illustrating the effect of the gas injection on scrubbing efficiency.

DESCRIPTION OF PREFERRED EMBODIMENTS AND EXAMPLES

In the preferred embodiments, the membrane cleaning regime may include a combination, in part or in whole, depending on the feed water quality, of one or more backwash methods.

A backwash or blowout, or a combination of both, may be used to dislodge the solids blocking the membrane pores.

The backwash is normally achieved by forcing the permeate in a reverse direction to filtration through the membrane pores. The backwash flow rate is usually in a range of 50 – 500% of the filtration flow, more commonly in a range of 100 – 300% of the filtration flow.

- 5 -

Blowout is another method of removing solids from the membrane pores by creating a rapid and explosive decompression within the filtration vessel. In this method, the two sides (feed side and permeate side) of a membrane are firstly pressurized to a specific value. Then the discharge valve on the feed side is opened to generate an instantaneous negative transmembrane pressure (TMP).
5 The solids in membrane pores are then blown out by the instantaneous negative TMP. As described below, in one embodiment, the blowout can also be integrated into a high velocity sweep step.

Another method of removing solids build-up from the membrane walls uses gas scouring to exfoliate the membrane surface. This method uses gas
10 bubbles moving past the membrane surface to achieve an efficient scrubbing. Gas scouring is widely used in the membrane filtration processes where suction is applied to the permeate side of the membrane wall to induce filtration. For the pressurized membrane filtration systems, gas scrubbing is achieved by injecting
15 gas, usually air, into the bottom end of the membrane module while the permeate is withdrawn from the upper end, as described in Japanese Patent No. JP2031200 and United States Patent No. 5,209,852.

After the backwash step, the solids removed from the membranes are normally removed from modules by draindown of the waste. The velocity during
20 a normal draindown is limited by the gravity force on the liquid within the vessel. The shear force thus generated is weak and may not be high enough to flush accumulated solids out of the modules and/or strip solids off the surface of the membrane. The situation is more manifest in hollow fibre membrane modules having a high fibre packing density.

- 6 -

Referring to Figures 1 and 2, a preferred embodiment of one form of module cleaning will be described.

Figure 1 illustrates a membrane module assembly 5. A hollow fibre membrane module 6 is located in a vessel 7. The module 6, in this example, contains a plurality of porous hollow fibre membranes 8, the ends the fibres opening into respective upper and lower permeate collection headers 9 and 10. Filtration takes place by applying feed to the outer wall of the fibres and withdrawing permeate through the fibre lumens. Filtrate/permeate is removed from both ends of the module 6 through ports 11 and 12 connected to headers 9 and 10 respectively. Feed inlet ports 13 and 14 and waste discharge ports 15 and 16 are provided at the upper and lower ends of the vessel 7, respectively. Valves AV1 and AV2 control the flow of feed to ports 13 and 14 while valves AV8 and AV5 control the flow of scouring gas. The flow of filtrate or permeate from the headers 9 and 10 is controlled by valves AV3 and AV4 while backwash flow to these headers is controlled by valves AV7 and AV4. Valves AV5 and AV6 control waste discharge from ports 15 and 16.

The steps of the process will now be described with reference to Figures 2a to 2d.

Step 1. Filtration. During a typical dead-end filtration process, valves AV1-4 are open. The raw feed water is fed via valves AV1 and AV2 entering the upper and lower inlet ports 13 and 14 while the permeate is withdrawn from the top and bottom ports 11 and 12 of the module 6 (as best shown in Figure 2(a)).

Step 2. Air scouring. At the end of the filtration step, valves AV1- 4 are closed, and then the upper discharge valve AV5 and the gas inlet valve AV8 are open.

- 7 -

Gas (usually air) is then introduced into the module 6 through valve AV8 and the lower port 14 to scour the membrane as illustrated in Figure 2(b).

Step 3. Pressurization via backwash. When the gas scouring stops, valves AV5
5 and AV8 are closed. The vessel 7 is left partly filled with gas and water. A permeate backwash is initiated by opening valves AV4 and AV7. The pressure in the vessel 7 gradually increases during the backwash to pressurize the remaining gas within the vessel 7 (see Figure 2 (c)) and finally the pressure on both sides of the membrane walls equalizes. A pressurized gas pocket is thus
10 formed within the vessel 7.

Another way to create such a gas pocket is to drain down or partly drain down the liquid waste at the end of the filtration Step 1 or after the gas scouring in Step 2. In this case it takes longer time to pressurize the gas, and consumes more permeate, but will achieve a higher average sweep velocity. The sweep
15 velocity is desirably greater than 0.03m/sec and preferably in the range 0.3 m/sec to 2.0 m/sec.

Step 4. Blowout and high velocity sweep down (Figure 2 (d)). When the pressure on the permeate side approaches that on the feed side of the
20 membrane wall, which is also the maximum discharge pressure of the backwash pump, valve AV6 is opened. An instantaneous negative TMP is generated across the membrane wall, which achieves a second backwash of the membrane pores. Simultaneously, the high-pressure gas pocket formed on the feed side rapidly expands and sweeps down the solids out of the membrane
25 module at a high velocity through port 16. The high velocity sweep may also

- 8 -

create a high shear force to assist scrubbing the membrane surface. The maximum negative TMP and sweep velocity that can be achieved depend on the resistance in the drain line and the pressure on the permeate side of the membrane. At the end of the fast drain, the backwash pump is stopped and
5 valves AV6 and AV7 are closed. The sequence then returns to the start of filtration.

The process described above generates both a blowout effect and a fast drain-down of the vessel 7. Therefore good cleaning efficiency can be achieved. Other means to achieve a high velocity sweep may include the use of the feed
10 pump to deliver a sweep flow or employing compressed air/gas applied to the vessel housing the module or an external vessel, to achieve a high velocity sweep. An external vessel may be used where formation of a pressurized gas bubble within the feed containing vessel is difficult due to module configuration. In such an arrangement a gas containing region is provided within a further
15 vessel coupled to said feed-containing vessel. The feed-containing vessel and the further vessel are sealed as a whole following said cleaning step and pressure applied to gas within the gas containing region to pressurize said gas, the pressure is then released by opening the feed-containing vessel to atmosphere so as to cause the pressurized gas to expand and produce said
20 high velocity sweep of the feed-containing vessel. An external vessel may also be selectively coupled by a valve to the feed-containing vessel and contain pressurized gas and/or liquid which is released by opening the valve into the feed containing vessel to produce the high velocity sweep.

A further method of achieving a highly efficient sweep is to change the
25 sweep direction (upwards and downwards sweep) from time to time. The times

of the sweep in one direction and the frequency of change of the sweep direction depend on the module configuration, feed water quality and the operating conditions of the filtration system.

It will be appreciated that the method of cleaning membranes described
5 above can also be applied to the inside-out filtration process, filtration by suction and other types of membranes, including flat sheet, tubular, spiral wound as well as other configurations.

A number of tests were conducted using different cleaning regimes. These tests are described below.

10 Example 1: Short term tests

A hollow fibre membrane module with a surface area of 33 m² (based on OD) was installed in a process illustrated in Figure 1. Filtration was conducted by pressurizing the shell side of the module for 10 minutes and at a flux of 52 L/m²/hr. The feed water quality was poor with a turbidity of 35 NTU. At the end
15 of filtration a membrane cleaning procedure was started. The following cleaning strategies were conducted and the cleaning efficiency is compared in Figure 3.

Strategy 1: Permeate backwash only. The cleaning protocol involved the permeate backwash only at a flow rate of 3.2 m³/hr and a duration of 15
20 seconds. Solids were removed by pumping the feed water at a flow rate of 3.5 m³/hr from the lower inlet port and sweeping out of the module through valve AV5 for 38 seconds. The TMP kept rising after each backwash, indicating poor backwash efficiency.

- 10 -

Strategy 2: Air scouring and permeate backwash. The cleaning strategy included a pre-aeration for 15 seconds at an air flow rate of 8 m³/hr and then the permeate backwash similar to Strategy 1 plus a continued aeration for 15 seconds. The solids were removed by the normal sweep as in Strategy 1. The
5 TMP dropped after such cleans and a better cleaning efficiency was achieved.

Strategy 3: High velocity sweep down. The sequence was air scouring for 15 seconds, gravity drain down of waste (5 seconds), permeate backwash with the shell side valves closed till the pressure at the permeate side reached 480 kPa
10 (20 seconds), then opening the drain valve to achieve a blow-out and high velocity sweep down (10 seconds). Figure 3 shows that such a high velocity sweep-down further recovered TMP and removed the foulant on the membranes. The high velocity sweep not only removed accumulated solids from the module, it also provided further scouring of the membrane surfaces.

15

Strategy 4: Similar to Strategy 3 with a slightly different time scale: gravity drain for 10 seconds, backwash and pressurization for 30 seconds followed by high velocity sweep down for 5 seconds. Similar effect to Strategy 3 was recorded.

The above strategies were repeated and the results illustrated
20 effectiveness of the high velocity sweep down in removing accumulated solids from module.

Example 2: Extended test on effect of high velocity (HV) sweep

An extended test was conducted in the same pilot machine and on the
25 same site as in Example 1. The strategy combining air scouring and permeate

- 11 -

backwash (Strategy 2 in Example 1) was used to clean the membranes. Fouling of the membrane was reflected in the TMP rise during a constant flux operation process. The TMP change profile was recorded on a data logger device and Figure 4 illustrates the TMP profile. After three days (October 30 – November 2) TMP rose by 5.5 kPa. Then the control program was changed to allow one high velocity sweep (Strategy 4 in Example 1) for every eight-hours of operation. The TMP was quite stable during the next six days and only a rise of 1 kPa was recorded. On November 8, the special high velocity sweep was removed and the TMP increased rapidly without the fast sweep. The extended test again illustrated the effectiveness of the high velocity sweep in cleaning of membranes.

A further aspect of the invention relates to an improved gas scouring method where permeate can be withdrawn from both ends of the module. According to this aspect there is provided a method of cleaning a membrane filtration module, said module including at least one elongate membrane positioned in a feed-containing vessel, the membrane having a permeable wall which is subjected to a filtration operation wherein feed containing contaminant matter is applied to one side of the membrane wall and filtrate is withdrawn from the other side of the membrane wall, the method comprising the steps of:

- a) suspending the filtration operation;
- b) dislodging contaminant matter from said membrane wall into liquid surrounding the membrane by flowing gas bubbles along the one side of the membrane wall, said gas bubbles being formed by feeding gas into said feed-containing vessel through an opening therein.

Preferably, the opening is positioned laterally of the membrane.

- 12 -

In the prior art gas or air was introduced into the modules via the bottom port and the permeate taken from the top end only. The details of such a module configuration are described in United States Patent No. 6,156,200.

In the above examples 1 and 2, we have shown the introduction of gas into a module when the permeate is withdrawn from both ends. Figure 5 illustrates the module configuration and the ports for alternative gas injection. In this configuration, port 12 is connected to the gas source via valve AV9 and the backwash line through valve AV4 is removed. Permeate is withdrawn from one end through port 11.

10 There are two choices of introducing gas into the module 7. The first option is to introduce gas into the bottom pot of the module via port 12. Alternatively gas can be injected via shell side feed port 14. This method allows the application of gas scouring to the situation where the permeate is taken from both ends of a module. Figure 6 compares the TMP profile by changing the injection of gas into port 12 or 14. Under the same operating conditions, injecting gas into a different port did not produce any significant effect on the gas scrubbing efficiency.

15 It will be appreciated that further embodiments and exemplifications of the invention are possible with departing from the spirit or scope of the invention described.

20

CLAIMS:

1. A method of cleaning a membrane filtration module, said module including at least one membrane located in a feed-containing vessel, the membrane having a permeable wall which is subjected to a filtration operation
5 wherein feed containing contaminant matter is applied to one side of the membrane wall and filtrate is withdrawn from the other side of the membrane wall, the method comprising the steps of:
 - a) suspending the filtration operation;
 - b) performing a cleaning process on the membrane wall to dislodge
10 contaminant matter therefrom into liquid surrounding the membrane;
 - c) performing a high velocity sweep of the feed-containing vessel to remove the liquid containing the dislodged contaminant matter; and
 - d) recommencing the filtration operation.
2. The method according to claim 1 wherein the cleaning process of step b)
15 includes a fluid backwash of the membrane pores.
3. The method according to claim 2 wherein the fluid backwash includes a liquid backwash.
4. The method according to claim 2 or 3 wherein the fluid backwash includes a gas backwash.
- 20 5. The method according to any one of the preceding claims wherein the velocity of the high velocity sweep is greater than about 0.03 m/sec.
6. The method according to any one of the preceding claims wherein the velocity of the high velocity sweep is in the range of about 0.3 m/sec to about 2.0 m/sec.

- 14 -

7. The method according to any one of the preceding claims wherein the cleaning process includes gas scrubbing of a surface of the membrane wall.
8. The method of any one of the preceding claims wherein the high velocity sweep of the feed-containing vessel is performed periodically in different
5 directions within the vessel during operation of the cleaning method.
9. The method of any one of the preceding claims wherein the membrane is a hollow fibre membrane and the filtrate is withdrawn from either or both ends of the hollow fibre membrane during the filtration operation.
10. The method of any one of the preceding claims including the following
10 further steps:
- a) forming a gas containing region within said feed-containing vessel following said cleaning step;
 - b) sealing the feed-containing vessel;
 - c) applying pressure to gas within the gas containing region to pressurize
15 said gas;
 - d) releasing said pressure by opening the feed-containing vessel to atmosphere so as to cause the pressurized gas to expand and produce said high velocity sweep of the feed-containing vessel.
11. The method of any one of claims 1 to 9 including the following further
20 steps:
- e) providing a gas containing region within a further vessel coupled to said feed-containing vessel;
 - f) sealing the feed-containing vessel and the coupled further vessel as a whole following said cleaning step;

- 15 -

- g) applying pressure to gas within the gas containing region to pressurize said gas;
- h) releasing said pressure by opening the feed-containing vessel to atmosphere so as to cause the pressurized gas to expand and produce said high velocity sweep of the feed-containing vessel.
- 5
12. The method of claim 10 wherein said gas containing region is formed by partially draining down feed liquid within said feed-containing vessel.
13. The method of claim 10 or 12 wherein step c) includes applying a fluid backwash to said membrane.
- 10 14. The method of any one of claims 1 to 9 wherein said high velocity sweep is produced by applying a source of pressurized gas to liquid within said feed-containing vessel.
- 15 15. The method of any one of claims 1 to 9 including providing a further vessel coupled to said feed-containing vessel wherein said high velocity sweep is produced by applying a source of pressurized gas to said further vessel.
16. The method of any one of claims 1 to 9 wherein said high velocity sweep is produced by pumping liquid to or from said feed-containing vessel.
17. A method of cleaning a membrane filtration module, said module including at least one elongate membrane positioned in a feed-containing vessel, the membrane having a permeable wall which is subjected to a filtration operation wherein feed containing contaminant matter is applied to one side of the membrane wall and filtrate is withdrawn from the other side of the membrane wall, the method comprising the steps of:
- 20
- c) suspending the filtration operation;

- 16 -

- d) dislodging contaminant matter from said membrane wall into liquid surrounding the membrane by flowing gas bubbles along the one side of the membrane wall, said gas bubbles being formed by feeding gas into said feed-containing vessel through an opening in the vessel.
- 5 18. A method according to claim 17 wherein the opening is positioned laterally of said membrane.
19. A method according to claim 17 or 18 wherein the opening provides a feed inlet to said feed-containing vessel during said filtration operation.
20. A method according to any one of claims 17 to 19 wherein said gas is fed
10 under pressure into said feed-containing vessel.
21. A method according to claim 7 wherein said gas scrubbing includes dislodging contaminant matter from said membrane wall into liquid surrounding the membrane by flowing gas bubbles along the one side of the membrane wall, said gas bubbles being formed by feeding gas into said feed-containing vessel
15 through an opening in the vessel.
22. A method according to claim 21 wherein the opening is positioned laterally of said membrane.
23. A method according to claim 21 or 22 wherein the opening provides a feed inlet to said feed containing vessel during said filtration operation.
- 20 24. A method according to any one of claims 21 to 23 wherein said gas is fed under pressure into said feed-containing vessel.

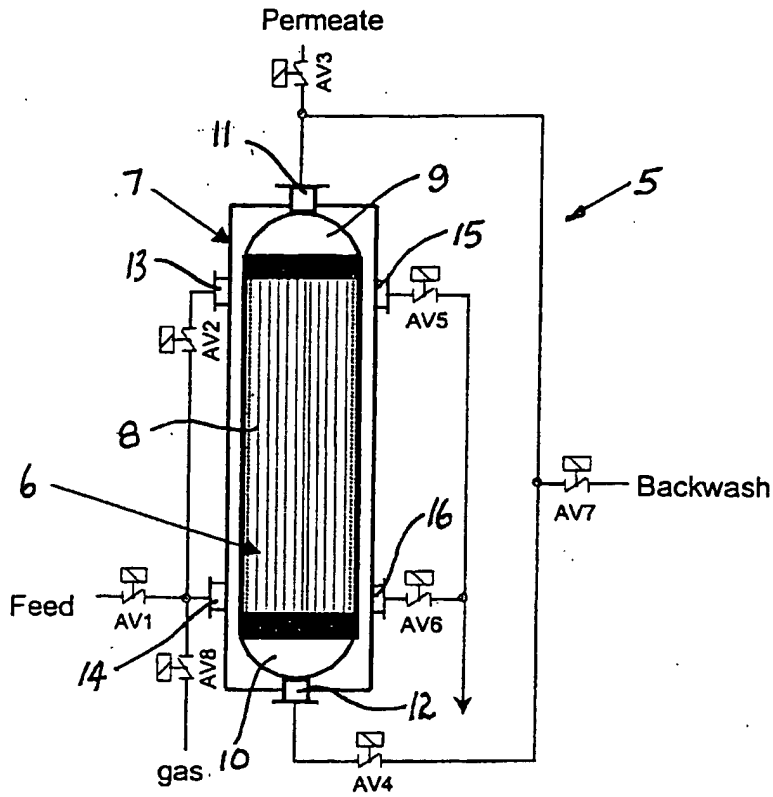
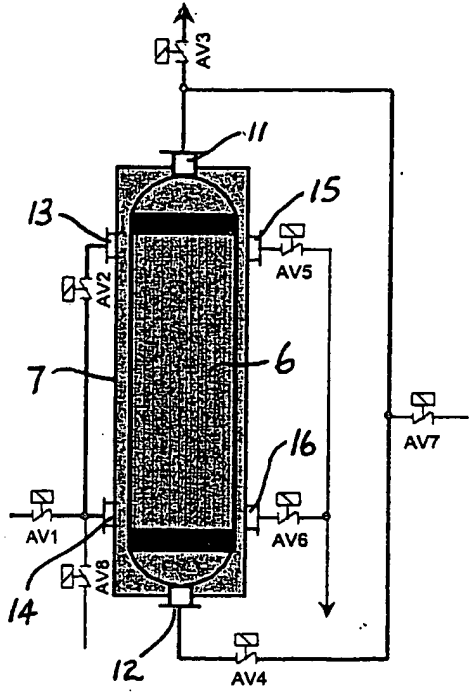
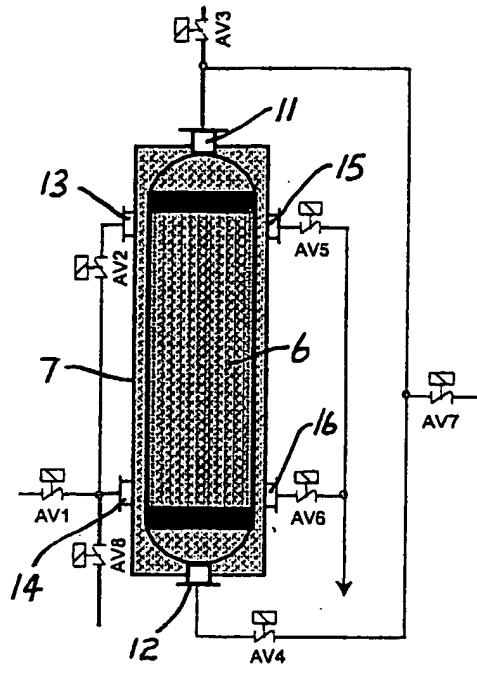

Figure 1 Membrane Module Assembly



(a) Filtration



(b) Air scouring

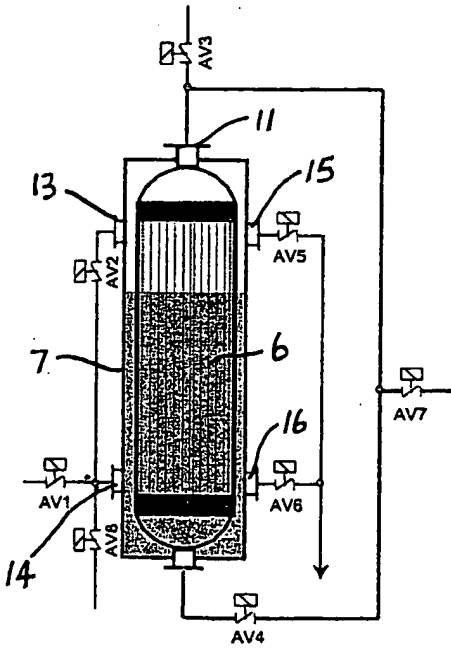

(c) Pressurization via backwash

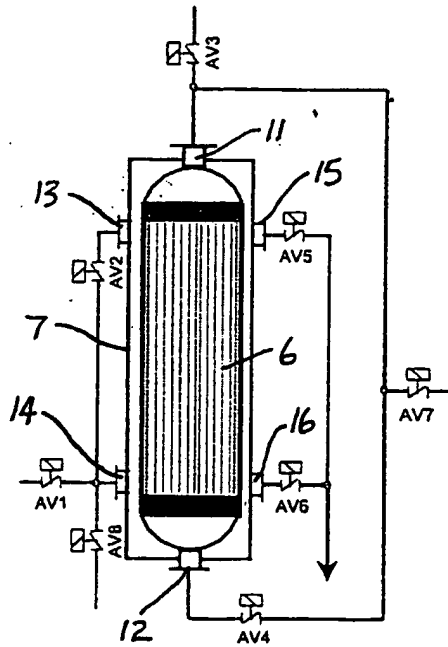

(d) Blow-out and fast drain-down

Figure 2 Membrane Cleaning Sequence

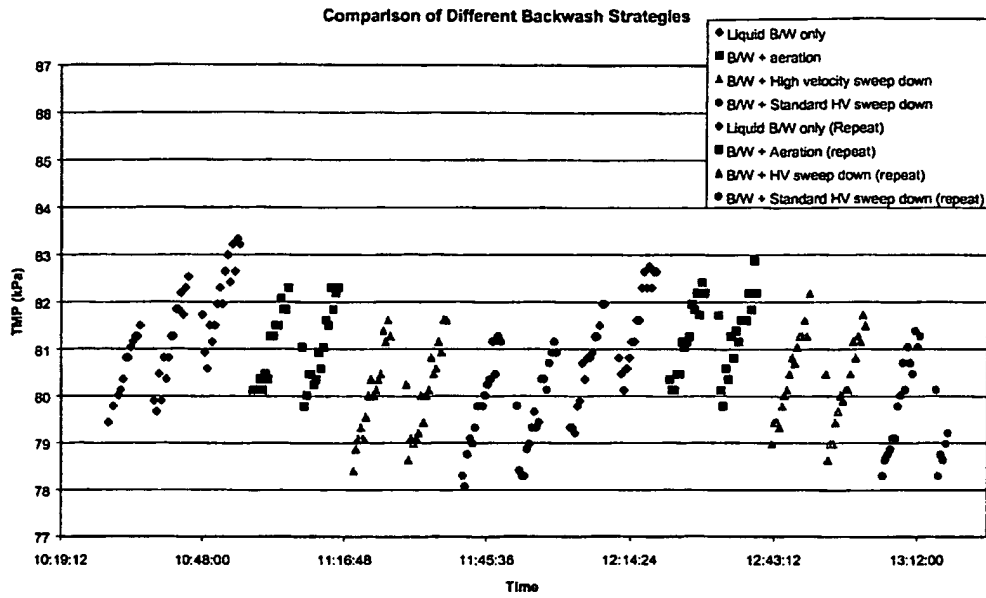

Figure 3 Cleaning Efficiency of Different Strategies

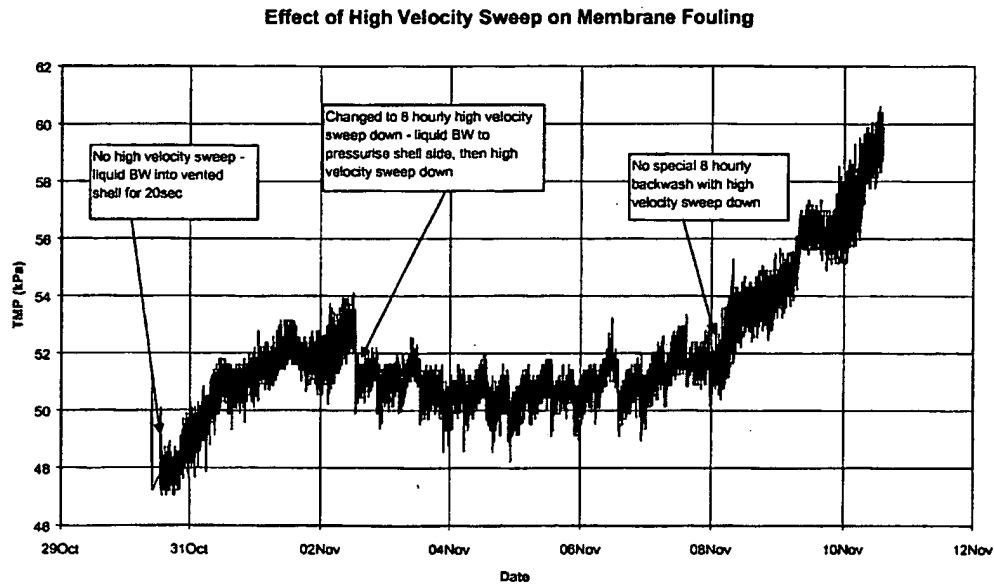

Figure 4 Effect of High velocity Sweep on Membrane Cleaning

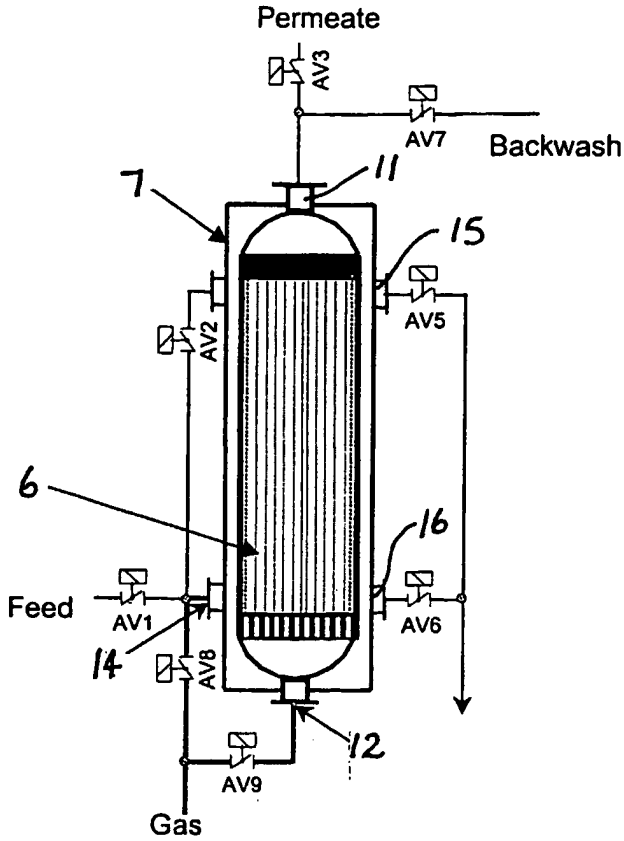

Figure 5 Alternative Air Injection

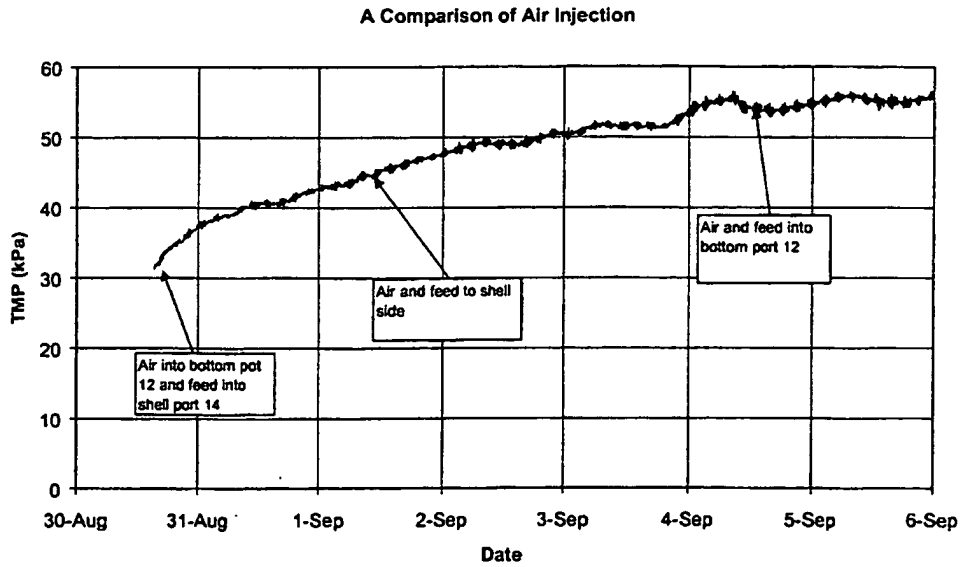

Figure 6 Effect of Alternative Air Injection on Scrubbing Efficiency

INTERNATIONAL SEARCH REPORT

International application No.
PCT/AU02/01065

A. CLASSIFICATION OF SUBJECT MATTER		
Int. Cl. ⁷ : B01D 65/02		
According to International Patent Classification (IPC) or to both national classification and IPC		
B. FIELDS SEARCHED		
Minimum documentation searched (classification system followed by classification symbols) B01D 65/02		
Documentation searched other than minimum documentation to the extent that such documents are included in the fields searched		
Electronic data base consulted during the international search (name of data base and, where practicable, search terms used) DWPI + (SWEEP+ OR +BUBBL+)		
C. DOCUMENTS CONSIDERED TO BE RELEVANT		
Category*	Citation of document, with indication, where appropriate, of the relevant passages	Relevant to claim No.
X,Y	WO,A,200136075 (ZENON ENVIRONMENTAL INC) 25 May 2001 See whole document	1-9,16-24
X Y	WO,A,9607470 (MEMTEC LIMITED) 14 March 1996 See whole document	1-6,8-16 7,21-24
X Y	WO,A,9822204 (MEMTEC AMERICA CORPORATION) 28 May 1998 See whole document	1-6,8,9,16 7,21-24
<input checked="" type="checkbox"/> Further documents are listed in the continuation of Box C <input checked="" type="checkbox"/> See patent family annex		
* Special categories of cited documents:		
"A" document defining the general state of the art which is not considered to be of particular relevance	"T" later document published after the international filing date or priority date and not in conflict with the application but cited to understand the principle or theory underlying the invention	
"E" earlier application or patent but published on or after the international filing date	"X" document of particular relevance; the claimed invention cannot be considered novel or cannot be considered to involve an inventive step when the document is taken alone	
"L" document which may throw doubts on priority claim(s) or which is cited to establish the publication date of another citation or other special reason (as specified)	"Y" document of particular relevance; the claimed invention cannot be considered to involve an inventive step when the document is combined with one or more other such documents, such combination being obvious to a person skilled in the art	
"O" document referring to an oral disclosure, use, exhibition or other means	"&" document member of the same patent family	
"P" document published prior to the international filing date but later than the priority date claimed		
Date of the actual completion of the international search 25 September 2002	Date of mailing of the international search report - 4 OCT 2002	
Name and mailing address of the ISA/AU AUSTRALIAN PATENT OFFICE PO BOX 200, WODEN ACT 2606, AUSTRALIA E-mail address: pct@ipaustalia.gov.au Facsimile No. (02) 6285 3929	Authorized officer M.R. OLLEY Telephone No : (02) 6283 2143	

INTERNATIONAL SEARCH REPORT

International application No.

PCT/AU02/01065

C (Continuation). DOCUMENTS CONSIDERED TO BE RELEVANT		
Category*	Citation of document, with indication, where appropriate, of the relevant passages	Relevant to claim No.
X Y	WO,A,9706880 (ZENON ENVIRONMENTAL INC.) 27 February 1997 See whole document	17-20 7,21-24
X Y	WO,A,9828066 (MEMTEC AMERICA CORPORATION) 2 July 1998 See whole document	17-20 7,21-24
X Y	WO,A,200018498 (USF FILTRATION AND SEPARATIONS GROUP INC.) 6 April 2000	17-20 7,21-24
X Y	Derwent Abstract Accession No. 2001-568380/64, Class D15, J01 JP,A,2001205055(DAICEL CHEM IND LTD) 31 July 2001	17-20 7,21-24
X Y	Derwent Accession No. 85-064514/11, Class J01, JP,A,60019002(NIPPON GENSHIRYOKU JIGYO) 31 January 1985	17-20 7,21-24
X Y	Derwent Accession No. 95-370600/48, Class J01, JP,A,07251043(TOTO LTD) 3 October 1995	17-20 7,21-24

INTERNATIONAL SEARCH REPORT

Information on patent family members

International application No.

PCT/AU02/01065

This Annex lists the known "A" publication level patent family members relating to the patent documents cited in the above-mentioned international search report. The Australian Patent Office is in no way liable for these particulars which are merely given for the purpose of information.

Patent Document Cited in Search Report	Patent Family Member				
WO 200136075	AU 200113764 EP 1146955 US 6325928 EP 1140330	AU 200113767 PL 348909 WO 200030742	EP 1146954 WO 200136074 AU 200012558		
WO 9607470	AU 34661/95 EP 779835	CA 2199356 US 6159373	CN 1159769		
WO 9822204	AU 49361/97				
WO 9706880	AU 66528/96 EP 1170052 US 5910250 US 6193890 AU 14308/99	EG 21552 EP 1213048 US 5944997 US 6294039 EP 1053054	EP 846023 US 5783083 US 6042677 US 5639373 WO 9929401		
WO 9828066	AU 53957/98 NZ 336455	CN 1244814 NZ 510245	EP 952885		
WO 200018498	AU 61834/99	EP 1115474	US 2001047962		
END OF ANNEX					